

To avoid confusion during installation remove this page and router being installed pages, return others to box.

Caution: Before and during installation of Router Raizer make sure power switch is in the off position and tool is disconnected from power source to avoid accidental starting of the tool which may result in personal injury.

# RZ 200 Parts Diagram

Parts Shown Full Size

Note: Actual mainshaft length 14 1/4"

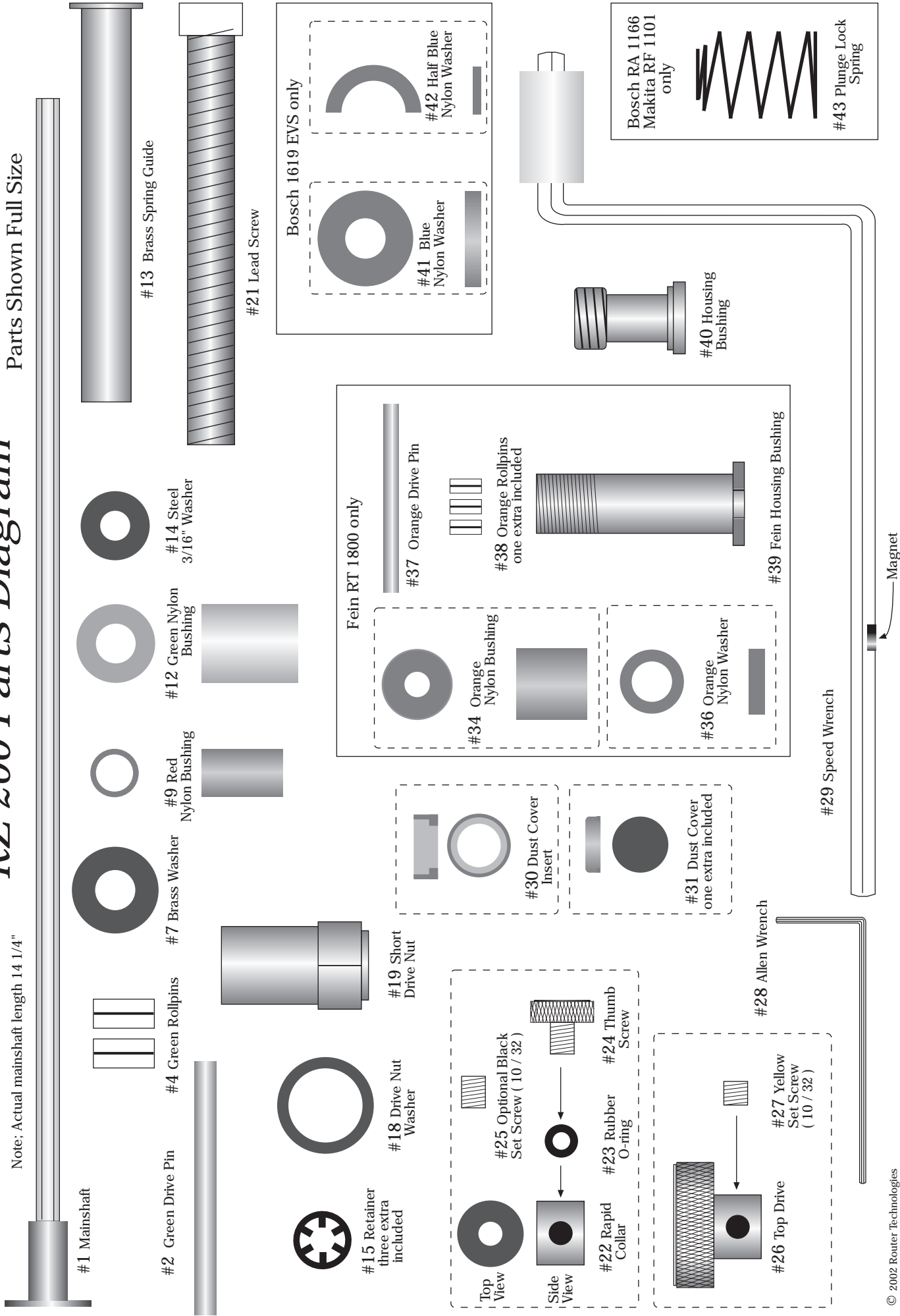

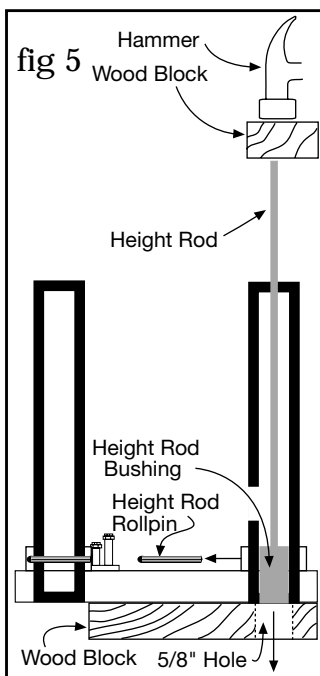
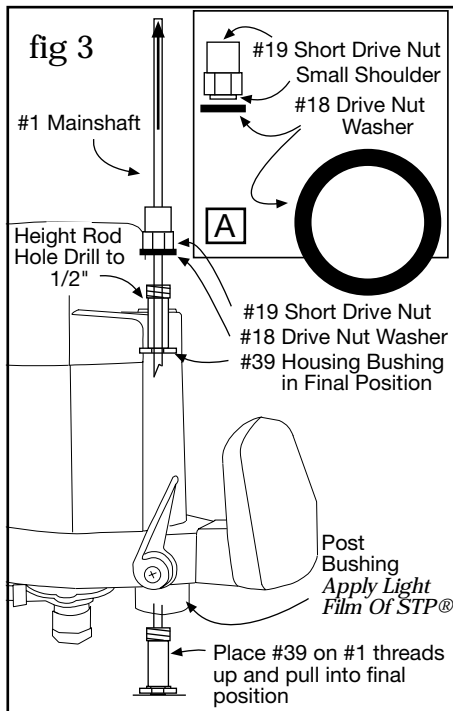
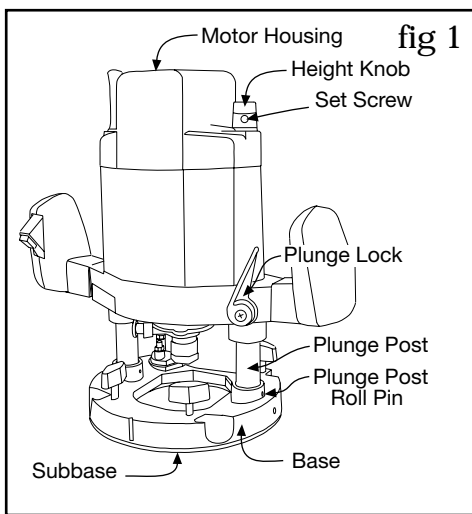

Tools Required: 11/16" wrench, 2.5 MM or 7/32" allen wrench, 1/8", 5/16" & 1/2" drill bits. Drill, Phillips screwdriver, hacksaw, hammer, center punch,

Router Raizer Parts Required: #1, #7, #12, #13 (three #15) # 18, #19, #21, #22, #23, #24, #26, #27, #28, #29, #34, #36, #37, #38, #39, #30, & #31 for router table installation.

For visual reference of parts installed. See (fig 9) back of page before installation.

## Separating Motor Housing from Base

- Using (fig 1) Remove and set aside subbases with screws. Stand router upright secure plunge lock. Remove height knob set screw with 2.5MM allen wrench, if 7/32" wrench is used, remove gently to avoid stripping set screw. Remove height knob and washer, store with set screw.
- Unlock plunge lock and lift motor off base. Remove and set aside plunge springs

## Preparing Motor Housing

- Select a 1/2" drill bit and drill. Using (fig 2) drill down through the motor housing height rod hole enlarging it to 1/2".  
*NOTE: Enlarging this hole will not affect reinstallation of original height rod.*

- Select #1Fein mainshaft, #39 housing bushing, #18 drive nut washer, #19 short drive nut. Using (fig 3), drop #39 housing bushing threads onto #1 mainshaft. Start #1 mainshaft into bottom of housing and push up through enlarged hole. Grasp top of #1 mainshaft and pull #39 bushing into final position. Drop #18 washer then #19 nut onto #1 mainshaft, and tighten #19 nut onto #39 bushing using 11/16" wrench. Remove #1 mainshaft

*NOTE: #18 washer must fit on small shoulder #19 nut compare to inset A (fig 3)*

*Tip: If #19 nut will not tighten insert long flat blade screwdriver from bottom into post bore to wedge #39 housing bushing while tightening #19 short nut*

- Using (fig 3) clean inside all post bushings. Apply a light film of STP® motor oil treatment. This lubricants anti-friction properties provides the smoothest possible plunge action, and helps prevent binding and chattering during use.

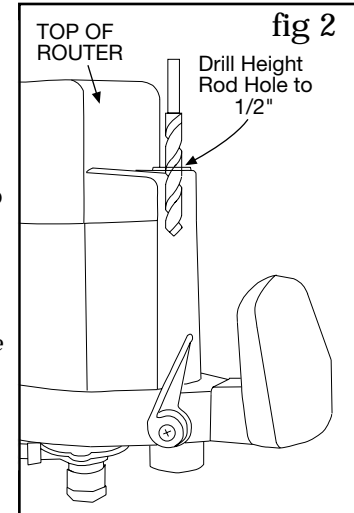

## Preparing the Base

- Select: hammer and #37 orange drive pin. Using (fig 4 & 5) Line #37 orange pin up with the height rod roll pin and drive roll pin from base.

- Prepare a wood block approx. 3/4" X 8" X 4" with a 5/8" hole drilled 1" from one end. Using (fig 5) stand base upright with height rod bushing centered over 5/8" hole. Place scrapwood block on top of height rod, drive height rod and bushing down out of the post. *NOTE: the height rod drives out extremely hard. Store height rod pin, height rod and bushing, and height knob.*

- The rollpin hole through the base and post will now be misaligned. Realign the holes by placing a socket on the bottom of the post. Using a hammer gently tap the post until holes align. Finish the alignment with the #37 orange drive pin or nail set.

- Select two #38 orange roll pins. Using (fig 6) replace the roll pin previously removed and realigned with the two orange roll pins one from each side. Tap in with hammer until flush, *TIP: Use needle nose pliers or tweezers to hold roll pins*
- Select #34 orange nylon bushing. Using (fig 6) turn base upside down with posts on scrap peice of wood. Drive #34 orange bushing into bottom of height rod post until flush with bottom of post. *TIP: this bushing drives in hard, sanding a slight chamfer on one end of the bushing aids in installation..* Once installed enlarge the hole #34 orange bushing to 21/64" or ream with 5/16" bit until #1 mainshaft head spins free when placed into bushing.

*Note: following step secures #34 orange bushing in the post with one #38 rollpin.*

- Using (fig 7) locate the threaded hole on the side of the base just below the #34 orange rollpin. Center a center punch in the hole, and tap with hammer. Select 1/8" drill bit and center the bit on the punch mark in the hole and drill through the post and #34 orange bushing.
- Insert #38 orange rollpin into the threaded hole. Drive it into the 1/8" hole just drilled using a center punch or #37 orange drive pin. Insert #1 maishaft must spin freely in #34 orange bushing, If it doesn't #38 rollpin is over driven, insert a punch or phillips screwdriver into #34 orange bushing to push rollpin back. Recheck free rotation of #1 mainshaft.

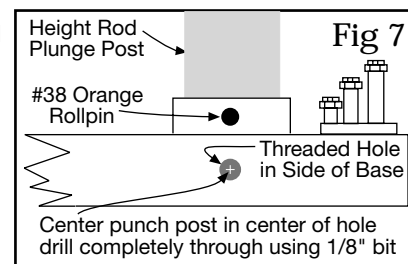
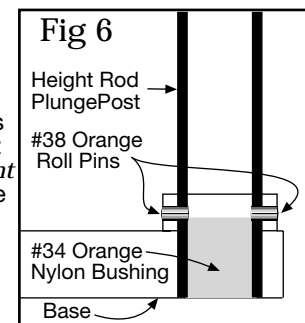
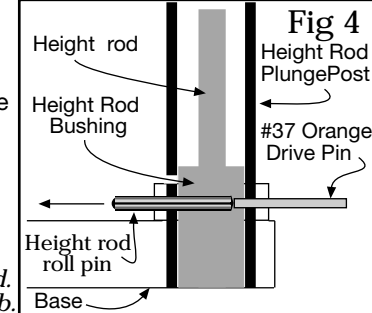

See other side to finish installation

## Installing mainshaft

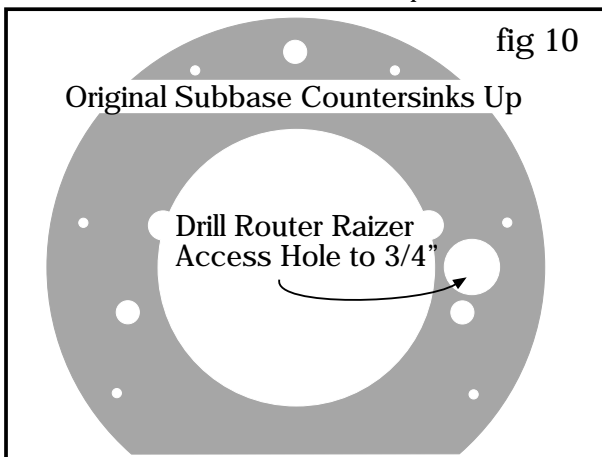
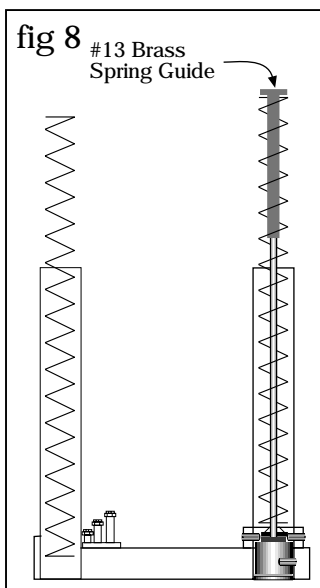
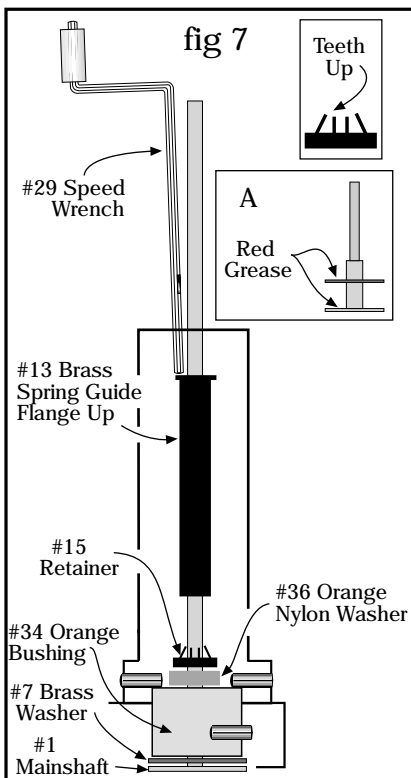

1. Select #1 mainshaft #13 brass spring guide, #7 brass washer, one #15 retainer. *Cut #1 mainshaft to 13" overall length and debur cut end.* Using (fig 7) Place small amount of red grease on mainshaft head (fig 7) box A. Drop #7 brass washer down mainshaft place grease on top of washer. Place #1 mainshaft with washer into #34 orange bushing, set base upright on bench. Place #36 orange washer on #1 mainshaft, drop down mainshaft into post. Place #15 retainer teeth up on top of mainshaft. Use #13 brass spring guide with flange up to start and push the retainer down the shaft and into the post. When brass flange meets top of post, set end of #29 speed-wrench on brass flange and push into post until tight. Remove and set aside #13 brass bushing. Check end play of mainshaft, if there is movement up and down, retighten with above step.

## Reassembling Router (Plunge Springs Must be Installed)

**NOTE:** for router table applications only! This router uses extremely stiff plunge springs for smoothest operation, reinstall only the #1 mainshaft side spring.

1. Stand base upright, replace both springs. Place #13 orange brass spring guide in top of #1 main shaft side-spring (fig 8) Unlock plunge lock. Grasp router handles and guide springs into motor housing. Align #1 mainshaft through #19 short drive nut, plunge router and engage plunge lock.

2. Select (Two #15 retainers) #21 lead screw, #22 rapid collar, #23 O-ring, #24 thumb screw, #26 top drive, #27-yellow set screw, #28 allen wrench, red grease. Using (fig 9) Place grease on threads of #21 lead screw, Place lead screw down #1 mainshaft and thread into #19 short-nut. Align hex end of mainshaft through hex in lead screw, thread in until one inch of mainshaft extends above the head #21 lead screw.

*Tip:* # 29 speed wrench can be inserted into top of lead screw or bottom of mainshaft to speed threading.

3. Press #23 O-ring onto #24 thumb screw shaft. Thread thumb screw into #22 rapid collar. Place rapid collar onto #1 mainshaft 1/2" from top of mainshaft to top of rapid collar and tighten (fig 9). Release plunge lock and slowly raise the router until lead screw contacts the rapid collar. If the collar moves, reset to 1/2". Place one #15 retainer teeth up on top of #1 mainshaft use #12 green nylon bushing to start and push #15 retainer into contact with collar, repeat with second #15 retainer push flush with first retainer. Remove and store green bushing. Place #26 top drive onto #1 mainshaft until it contacts retainer clip, Thread #27 yellow set screw into #26 top drive using #28 allen wrench and tighten.

## Sub-base or Router Table Insert Installation

1. Place Fein template lettering up onto original subbase (counter sunk side up). Line up holes and center punch Router Raizer access point, drill to 3/4". reattach the sub-base. Use the three large router plate mounting holes for router table applications. See (fig 10)
2. See pages 12 & 13 for further instruction, #30 dust cover insert and #31 dust cover, are router table only. Drill a 1/2" hole through insert plate at the Raizer access point and press #30 in from top until flush. # 31 sets in #30 and is removed during adjustments with magnet on back edge of # 29 speed handle. These components keep dust from entering the Router Raizer hex drive.

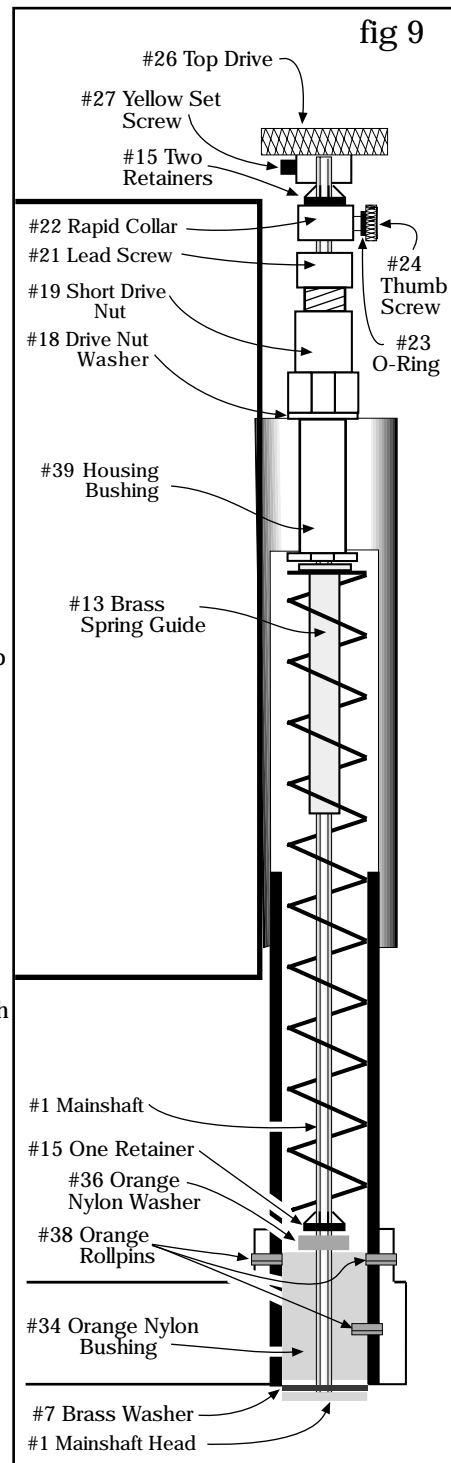

Periodic inspection and re greasing of #21 lead screw is recommended.

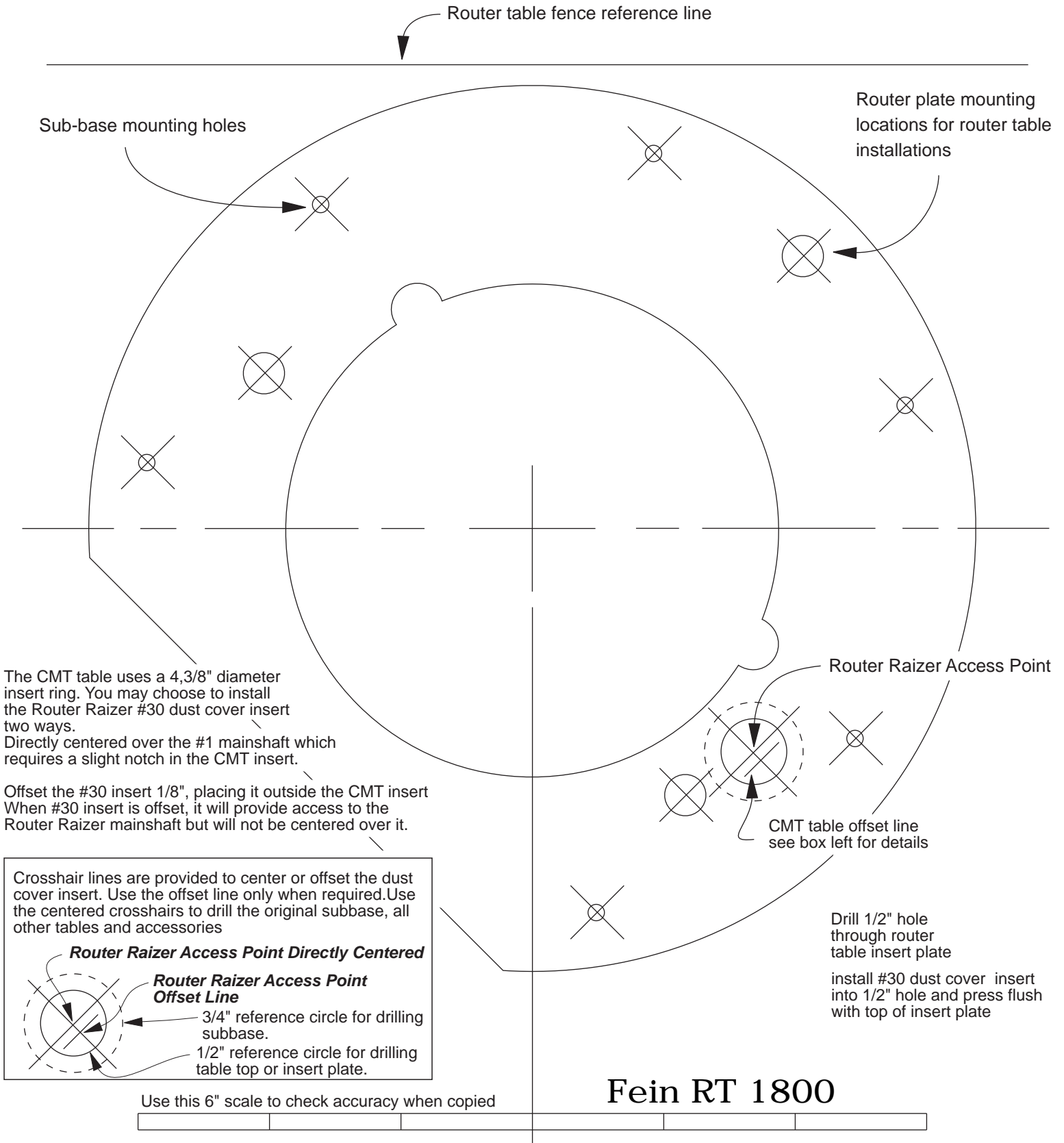

The CMT table uses a 4.3/8" diameter insert ring. You may choose to install the Router Raizer #30 dust cover insert two ways. Directly centered over the #1 mainshaft which requires a slight notch in the CMT insert.

Offset the #30 insert 1/8", placing it outside the CMT insert. When #30 insert is offset, it will provide access to the Router Raizer mainshaft but will not be centered over it.

Crosshair lines are provided to center or offset the dust cover insert. Use the offset line only when required. Use the centered crosshairs to drill the original subbase, all other tables and accessories

**Router Raizer Access Point Directly Centered**

**Router Raizer Access Point Offset Line**

3/4" reference circle for drilling subbase.

1/2" reference circle for drilling table top or insert plate.

Drill 1/2" hole through router table insert plate

install #30 dust cover insert into 1/2" hole and press flush with top of insert plate

Use this 6" scale to check accuracy when copied

# Fein RT 1800

**Note:** Cross lines for locating and drilling holes are accurate. The illustration of subbase may vary slightly in size and design, but is accurate enough for cutting the rubber gasket if required.

## Templates

Individual templates are provided for locating router base, bolt patterns and the Router Raizer access hole. The templates locate holes on both the original subbase, and router table insert plates. *Caution: Photocopying templates may result in reference marks not reproducing accurately. Place photocopy on original and hold up to window to view accuracy of registration.*

### Duplicating Templates

Additional templates available free off website [www.routertechnologies.com](http://www.routertechnologies.com) ( If website access is unavailable follow step below )  
Duplicating the template allows original to be used multiple times. Place original template on a blank sheet of paper. lay both on a carpet floor. Place one straight pin through center crosslines, use second straight pin to pierce through remaining crosslines. Remove original and circle pin holes to be used.

### Using Template

1. When using either the original or duplicate template, always double check before drilling. *If Template is used upside down, the Router Raizer access hole will be on the wrong side!*
2. To avoid placing the Router Raizer access hole under the fence, all templates have a router table fence reference line. When aligned to the back edge of the router table insert plate, or fence the router is offset placing the Router Raizer access hole in front of the fence.
3. To center template on a router table insert plate, align the center cross lines on the template to the center hole in the insert plate. Measure the center hole in the router table top or insert plate. Center an inexpensive compass on the center crosshairs and transfer the circle to both sides of the template. Tape the template to the insert. Make sure template is on correctly ( see step above ) drill holes.

### Mounting original Subbase or Router Table Insert Plate

*Due to variations in mounting subbase or table insert plate, please read instructions below and back of page before drilling any holes.*

1. **Drilling Original Subbase.** Using ( fig 2 ) align template mounting holes with the subbase holes. Mark the Router Raizer access point onto the subbase. Before drilling, place subbase on router base, check the Raizer access point is over the mainshaft head. When marked properly drill a 3/4" access hole through the subbase and install onto router.

*Caution: The 3/4" Hole is Through the Original Subbase Only.*

*Never Drill a 3/4" Hole in Any Router Table Insert Plate or Router Table Top.*

*On some routers the #1 mainshaft head may not be flush with the bottom of the router base. Shown fig 1.*

To determine if mainshaft head is flush, sight, or lay a straight edge over the #1 mainshaft head. Shown fig 1. If head is below flush or flush with the base, proceed to step two below. If head is above the base proceed to back of page.

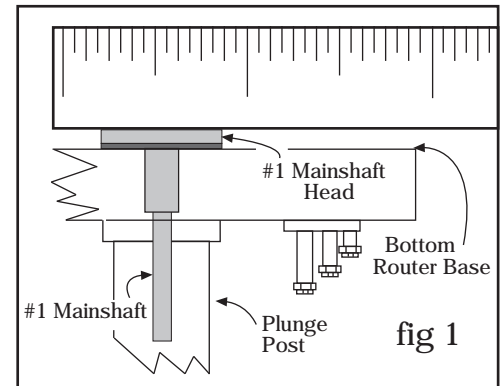

**Caution: Before drilling router table. Positioning template, place router under insert or table top and check Router Raizer access point, all hole locations, and possible router clearance problems.**

2. **Drilling Top of Router Table Insert Plate.** Using ( fig 3 ) Align template fence reference line with back edge of insert plate or fence. Place the template lettering up onto the insert or table top. Make sure router handles and controls are accessible and clear any obstacles. The template may be rotated to any position required, we recommend placing the Router Raizer access hole in front of the fence. When the template is positioned properly, center it to the insert hole by placing a compass on the template center cross lines. Rotate and size the compass until centered in insert hole. Center punch holes onto insert plate. recheck hole locations before drilling. Drill Router Raizer access hole 1/2" through insert. Drill mounting holes same as original subbase. See back of page for installing #30 dust cover insert and #31 dust cover into 1/2" Router Raizer access hole.

© 2002 Router Technologies

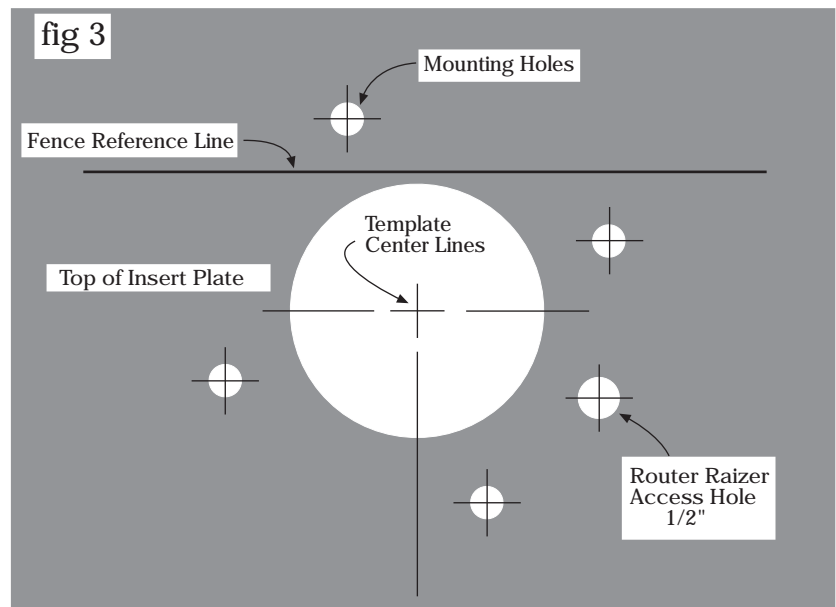
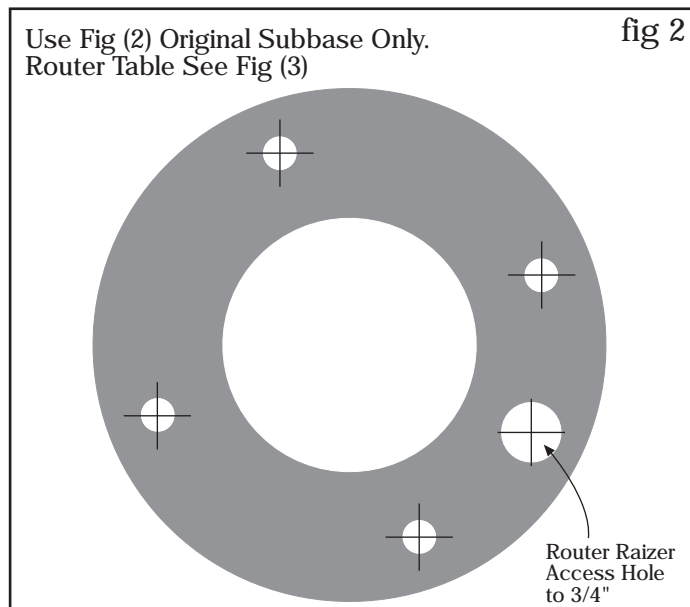

If mainshaft head is not flush with the base, use step below or rubber spacer gasket for mounting to table insert or router table top.

**Drilling Pocket in Back of Router Table Insert Plate.** Boring a pocket on the backside of the table insert or router table top provides clearance for the mainshaft head to rotate. *Caution; Do not drill pocket over 3/32" deep.* Note: The pocket requires a 3/8" or thicker insert plate. If insert plate is thinner than 3/8" or steel, use the 8" X 8" rubber spacer gasket. See instructions below.

1. With template properly located on insert or table top, center punch on crosshairs all router mounting holes and the Router Raizer access. Using a 1/8" drill bit, drill the Router Raizer access hole through the insert or table top. Turn insert or table top over ( fig 5 ) locate the 1/8" raizer access hole. Center a 3/4" spade or forsnor bit on the 1/8" hole and drill a pocket deep enough for the #1 mainshaft head to turn freely. Turn insert or table top over. Center a 1/2" drill bit on the 1/8" hole and drill completely through into the 3/4" pocket. Finish by drilling and countersinking remaining holes, and installing the dust cover insert. See below for instructions.  
*Caution: Do not drill pocket over 3/32" deep. #30 dust cover insert must be installed into top of 1/2" Raizer access hole. See installing dust cover insert below.*

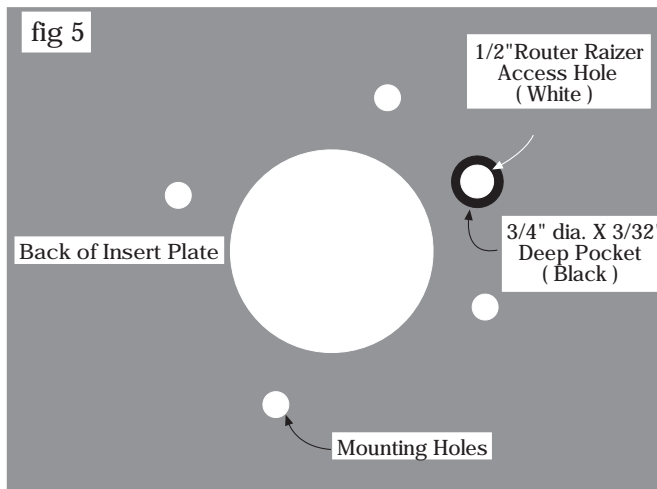
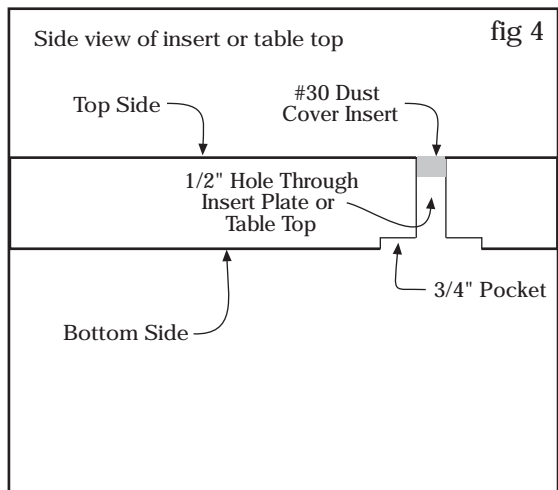

### Using the 8" X 8" Rubber Gasket

The 8" X 8" rubber gasket is provided for spacing #1 mainshaft head.

1. The easiest way to prepare the gasket is to first drill the Router Raizer access hole through the original subbase. Place the rubber gasket on a scrap piece of wood. Align the pre-punched 3/4" gasket hole and the Raizer access hole in subbase. Using ink pen, transfer mounting hole locations to the gasket. Using a utility knife or razor blade, hold the subbase in position while cutting around inside and outside of the subbase. Remove subbase and cut mounting holes. Using ( fig 6 ) place the gasket between the router base and subbase or insert.  
*Tip: mounting holes can be cut as square holes. If original subbase is unavailable the template may be used to cut the gasket.*

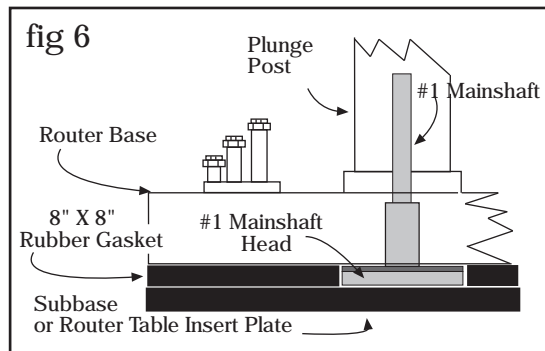

### Installing the Dust Cover Insert

1. Using ( fig 7 ) select #30 dust cover insert ( 1/2" dia, X 3/16" tall, turned aluminum ring ) and #31 dust cover ( 3/8" dia. X 1/8" thick stamped steel plug ) From top of insert plate, press #30 cover insert into the 1/2" Router Raizer access hole until flush.

*Tip: If cover insert fits loosely, secure with drop of Super Glue® or Crazy Glue®.*

2. Mount router to insert plate and install into table

3. Place #31 dust cover into #30 dust cover insert. Using ( fig's 7 & 8 ) remove #30 dust cover with magnet on back of #29 speed wrench. With dust cover on speed wrench, insert wrench to make adjustments. To reinstall dust cover, place cover into insert and slide wrench away. *Caution: Remove dust cover with speed wrench before removing router from table or cleaning table with vacuum sweeper.*

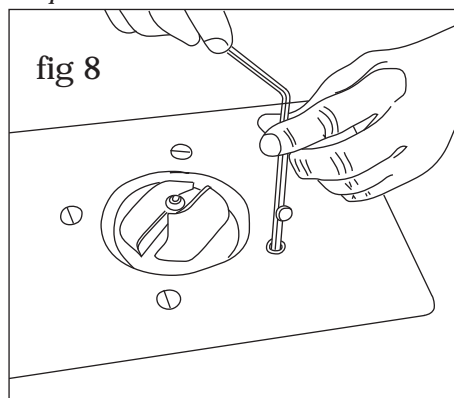
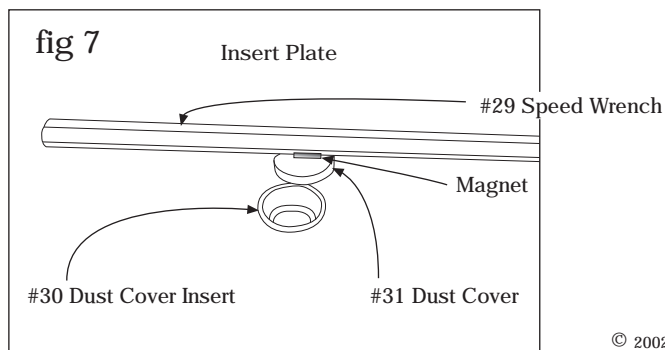

**Caution:** Always make sure router switch is in the off position, and tool is disconnected from power source when performing maintenance or making any adjustments to either the router or height adjustments to avoid accidental starting of tool which may result in personal injury.

## Using in a Router Table

### Dust Cover Insert and Dust Cover

The dust cover insert and dust cover allow easy adjustment access to the Router Raizer mainshaft and restricts dust and debris infiltration during use. A small magnet is recessed into speed wrench handle to remove and hold the dust cover during adjustments.

1. Removing dust cover: Using ( fig 1 ) place #29 speed wrench over #31 dust cover, lift speed-wrench to remove dust cover. Leave dust cover on wrench while making height adjustments.
2. Replacing dust cover: Position speed wrench with dust cover over the insert, press cover into insert and swipe wrench away leaving the dust cover in the insert.
3. Always remove #31 dust cover before removing router and insert from table. Or cleaning table with vacuum sweeper

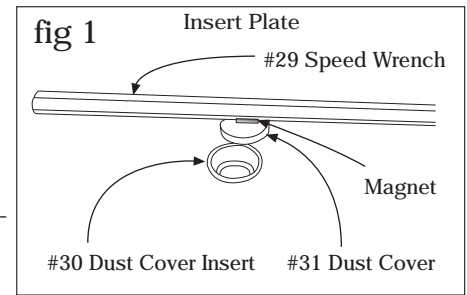

**Warning:** Never remove the dust cover while the router is running. Always wait until the bit has stopped spinning.

## Using Handheld

**Caution:** #22 rapid collar is for handheld operations only. For router table operation, lock #22 rapid collar in contact with #15 retainers.

**Caution:** Always make sure router switch is in the off position, and tool is disconnected from power source when performing maintenance or making any adjustments to either the router or height adjustments to avoid accidental starting of tool which may result in personal injury.

When used hand-held the hex shaped #1 mainshaft provides a constant engagement of the Router Raizer mechanism, allowing easy height adjustments while retaining original plunge capabilities and all other original functions of the router.

1. Height adjustments can be made from either end of the router. To adjust from the base, engage #29 speed wrench into the head of #1 mainshaft. To adjust from the top, engage #29 speed wrench into the top of #26 top drive. The knurled #26 top drive also allows adjustments by hand,

The #24 thumb screw and #22 rapid collar allow positioning the cutter to height, bypassing multiple revolutions of the speed wrench

1. Using ( fig 2 ) Adjust #21 lead screw, leaving approximately 1/2" exposed threads. Plunge router by hand 1/8" past desired height, and secure plunge lock.
2. Release rapid collar from position shown grey and slide down shaft to position shown black and lock in place.
3. Release plunge lock. Using speed wrench or top knob decrease depth of cut to desired position and engage plunge lock.
4. If #24 thumb screw will not provide enough pressure to secure #22 rapid collar, replace thumb screw with #25 optional black set screw and #28 allen wrench.

**Caution:** #22 rapid collar is not designed to maintain cutter height during routing operations. Always secure plunge lock before and during all routing operations.

## Direction of Rotation for Adjustment

**Adjustments from #26 top drive:**

Clockwise rotation Decreases depth of cut. Counterclockwise rotation Increases depth of cut.

**Adjustments from #1 Mainshaft Head :**

Clockwise rotation Increases depth of cut. Counterclockwise rotation Decreases depth of cut.

One complete rotation of the speedwrench, raises or lowers the bit 1/16"

**Caution:** Always secure plunge lock during routing operations.

## Transporting or Storing Router

Using ( fig 3 ) To prevent damage to the #1 mainshaft and #21 lead screw, adjust the lead screw leaving 1/2" threads exposed. Grasp router handles, release plunge lock, advance router up until lead screw rapid collar and retainers are all in contact, engage plunge lock.

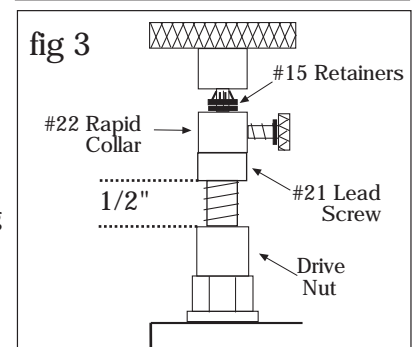
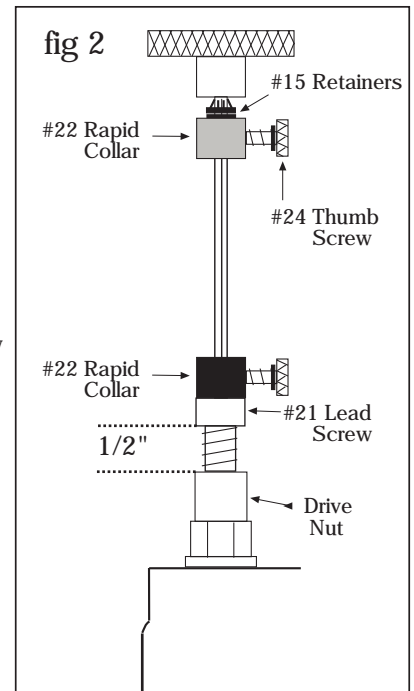

This instruction manual covers several different makes and models of plunge routers. The instructions are written for a person with some mechanical ability. If you understand the parts and operation of a plunge router, installing the Router Raizer is not difficult. Before beginning installation compare the illustrations and photos to your router, original subbase or router table insert plate. Understand the location and function of both original and Router Raizer parts. Keep all spare parts, instruction manual and templates for future reference. The Router Raizer can be removed from any router and reinstalled into another.

### *Responsibility of the Owner*

1. The responsibility of the owner is to follow the instructions, cautions, and warnings bellow and in the instructions
2. Know and understand the location of both original and Router Raizer parts.
3. Follow all the assembly instructions carefully.
4. Correctly adjust the components making sure the plunge action is smooth and plunge lock operates properly.
5. Carefully read and follow all notes, tips, cautions and warnings.
6. Make sure all operators of the Router Raizer know how to correctly use it.

*Important: Read, understand and follow instructions to avoid personal injury.*

*Caution: Before and during installation of Router Raizer make sure power switch is in the off position and tool is disconnected from power source to avoid accidental starting of the tool which may result in personal injury.*

*Caution: Always make sure router power switch is in the off position and disconnected from power source before and during any adjustments to the router or Router Raizer.*

*Warning: Never remove or reinstall #31 dust cover or make any depth of cut adjustments from either end of #1 mainshaft until router power switch is off, cutting tool has completely stopped rotating and tool is disconnected from power source.*

*Caution: Always secure plunge lock before and during routing operations.*

## ROUTER TECHNOLOGIES LIMITED TWO YEAR WARRANTY

Router Technologies warrants the Router Raizer to be free from defects in material and workmanship for a period of Two ( 2 ) Years from the original date of purchase to original owner. Our responsibility under this warranty is to replace, at no cost, any part which upon inspection at our facility is found to be defective in either material or workmanship. This warranty does not imply that the product is fit for a particular use or application, this warranty does not apply to parts which have been modified, altered, misused, damaged by improper storage. It also does not cover loss of parts during use, or mechanical adjustments which are covered in the instruction manual. In no event shall Router - Technologies be liable for any indirect, incidental or consequential damages from the sale or use of the product. This disclaimer applies both during and after the term of the warranty.

This warranty is your only remedy and parts are to be returned prepaid to our facility for inspection at Router Technologies, 2729 Delaware Ave, Des Moines, IA. 50317. This warranty gives you specific legal rights, and you may have other rights which may vary from state to state. Any legal actions must be brought in Polk County Iowa.